

**zFeatures**

- Loop Start Trunk Interface
- 900Ω Input Impedance
- 2-4 Wire Conversion
- On-Hook Reception
- Line State Detection Outputs:
  - Forward Loop
  - Reverse Loop
  - Switch Hook
  - Ringing Voltage
- Relay Driver
- Industrial Temperature Range option
- DIL and SMT versions
- Meets FCC part 68 Leakage Current Requirements

**Ordering Information**

MH88636AD-4I	28 Pin DIL Package
<b>-40°C to 85°C</b>	
MH88636AD-4	28 Pin DIL Package
MH88636AS-4	28 Pin SMT Package
<b>0°C to 70°C</b>	

**Description**

The Mitel MH88636-4 Central Office Trunk Interface circuit provides a complete analog and signalling link between audio switching equipment and a subscriber Line.

The device is fabricated as a thick film hybrid technology for optimum circuit design and very high reliability for both commercial and industrial temperature changes.

**Applications**

Interface to Central Office for:

- PABX
- Key Telephone Systems
- Channel Bank
- Voice Mail
- Terminal Equipment
- Digital Loop Carrier
- Optical Multiplexer

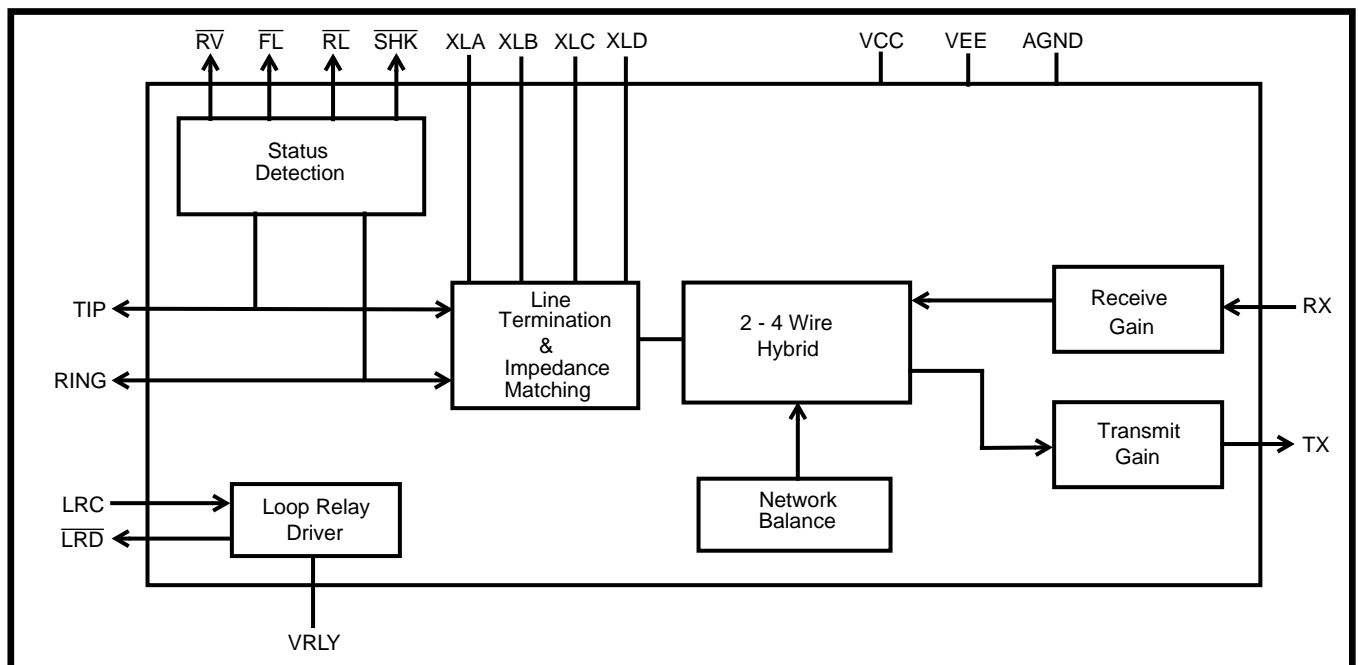

**Figure 1 - Functional Block Diagram**

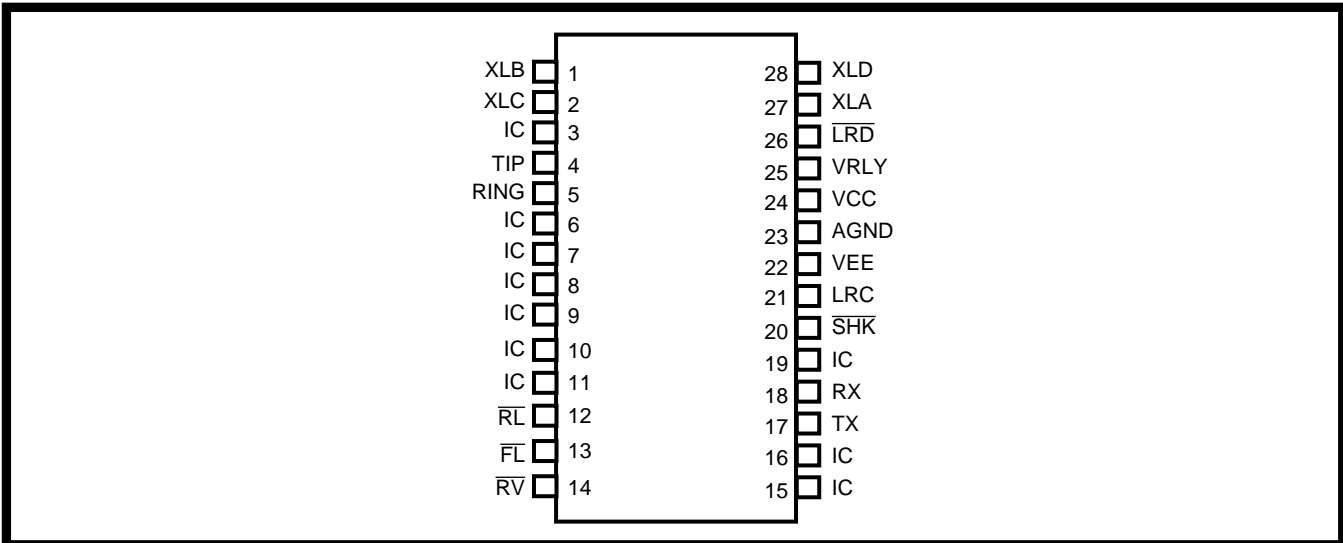

Figure 2 - Pin Connections

Pin Description

Pin #	Name	Description
1	XLB	<b>Loop Relay Contact B.</b> Connects to XLA through the Loop Relay contacts (K1) when the relay is activated.
2	XLC	<b>Loop Relay Contact C.</b> Connects to XLD through the Loop Relay contacts (K1) when the relay is activated.
3	IC	<b>Internal Connection.</b> No connection should be made to this pin.
4	TIP	<b>Tip lead.</b> Connects to the Tip lead of a Telephone Line.
5	RING	<b>Ring Lead.</b> Connects to the Ring lead of a Telephone Line.
6 - 11	IC	<b>Internal Connection.</b> No connection should be made to this pin.
12	RL	<b>Reverse Loop detect.</b> In the on-hook status, a logic 0 output indicates that reverse loop battery is present. In the off-hook state, a logic 0 output indicates that reverse loop current is present.
13	FL	<b>Forward Loop Detect.</b> In the on-hook status, a logic 0 output indicates that forward loop battery is present. In the off-hook state, a logic 0 output indicates that forward loop current is present.
14	RV	<b>Ringing Voltage Detect (Output).</b> A logic 0 indicates that ringing voltage is across the Tip and Ring leads.
15, 16, 19	IC	<b>Internal Connection.</b> No connection should be made to this pin.
17	TX	<b>Transmit (Output).</b> 4 Wire ground (AGND) referenced analog output.
18	RX	<b>Receive (Input).</b> 4 Wire ground (AGND) referenced analog input.
20	SHK	<b>Switch Hook (Output).</b> A logic 0 indicates the presence of forward or reverse battery when LRC is logic 0 and the presence of forward or reverse loop current when LRC is logic 1.
21	LRC	<b>Loop Relay Control (Input).</b> A logic 1 activates the Loop Relay Driver output (LRD).
22	VEE	<b>Negative Power Supply.</b> -5V DC
23	AGND	<b>Analogue Ground.</b> 4 Wire ground. Normally connected to System Ground.
24	VCC	<b>Positive Power Supply.</b> +5V DC
25	VRLY	<b>Relay Supply Voltage.</b> Typically +5V. Connects to the relay supply voltage.

**Pin Description (continued)**

26	$\overline{\text{LRD}}$	<b>Loop Relay Drive (Output).</b> Connects to the Loop Relay coil. When LRC is at a logic 1 an open collector output at $\overline{\text{LRD}}$ sinks current and energizes the relay.
27	XLA	<b>Loop Relay Contact A.</b> Connects to XLB through the Loop Relay (K1) contacts when the relay is activated.
28	XLD	<b>Loop Relay Contact D.</b> Connects to XLC through the Loop Relay (K1) contacts when the relay is activated.

**Functional Description**

The MH88636-4 is a Central Office Interface Circuit (COIC). It is used to correctly terminate a Central Office 2-Wire telephone line. The device provides a signalling link and a 2-4 Wire line interface between the telephone line and subscriber equipment. The subscriber equipment can include Private Branch Exchanges (PBX's), Key Telephone Systems, Terminal Equipment, Digital Loop Carriers and Wireless Local Loops.

All descriptions assume that the device is connected as in the application circuit shown in Figure 3.

**Isolation Barrier**

The MH88636-4 provides an isolation barrier which is designed to meet FCC Part 68 (November 1987) Leakage Current Requirements.

**External Protection Circuit**

An external Protection Circuit assists in preventing damage to the device and the subscriber equipment, due to over-voltage conditions. The type of protection required is dependant upon the application and regulatory standards. In Figure 3 the protection is shown in block form. Further details should be obtained from the specific country's regulatory body.

**Suitable Markets**

The MH88636-4 has a selectable Input Impedance of  $900\Omega$  or  $900\Omega + 2.16\mu\text{F}$ . This makes it suitable primarily for North America or Brazilian markets.

**Line Termination**

When LRC is at a logic 1,  $\overline{\text{LRD}}$  will sink current which energizes the Loop Relay (K1), connecting XLA to XLB and XLC to XLD. This places a line

termination across Tip and Ring. The device can be considered to be in an off-hook state and DC loop current will flow. The line termination consists of a DC resistance and an AC impedance.

When LRC is at a logic 0, the Line Termination is removed from across Tip and Ring. An external Dummy Ringer should be permanently connected across Tip and Ring and under these conditions is the only load on the line. The device can be considered to be in an on-hook state and negligible DC current will flow. The Dummy Ringer is a series AC load of typically ( $17\text{k}\Omega + 330\text{nF}$ ) which represents a mechanical telephone ringer and allows ringing voltages to be sensed. This load can be considered negligible when the line has been terminated.

Depending on the Network Protocol being used the line termination can seize the line for an outgoing call, terminate an incoming call, or if applied and disconnected at the correct rate can be used to generate dial pulse signals.

The DC line termination circuitry provides the line with an active DC load which is equivalent to a DC resistance of less than  $300\Omega$ , dependant upon the loop current.

**Ringing Equivalent Number**

The Ringing Equivalent Number (REN) is application specific. See the governing regulatory body specification for details.

**AC Input Impedance**

The Input Impedance ( $Z_{in}$ ) is the AC impedance that the MH88636-4 places across Tip and Ring in order to terminate the telephone line. It can be set to either  $900\Omega$  or  $900\Omega + 2.16\mu\text{F}$  by connecting an external impedance between XLA and XLD (Zext).

To select a  $900\Omega$  Input Impedance,  $1000\Omega$  must be connected across XLA and XLD.

To select a  $900\Omega + 2.16\mu\text{F}$  Input Impedance,  $1000\Omega + 360\Omega//2.2\mu\text{F}$  must be connected across XLA and XLD.

All connections should be kept as short as possible.

## Network Balance Impedance

The MH88636-4's Network Balance Impedance has been optimised for either of the two Input Impedances.

## 2-4 Wire Conversion

The device converts the balanced 2-Wire input, presented by the line at Tip and Ring, to a ground referenced signal at TX. This circuit operates with or without loop current; signal reception with no loop current is required for on-hook reception enabling the detection of Caller Line Identification (CLI) signals.

Conversely the device converts the ground referenced signal input at RX, to a balanced 2-Wire signal across Tip and Ring.

The 4-Wire side (TX and RX) can be interfaced to a filter/codec, such as the Mitel MT896X, for use in digital voice switched systems

During full duplex transmission, the signal at Tip and Ring consists of both the signal from the device to the line and the signal from the line to the device. The signal input at RX, being sent to the line, must not appear at the output TX. In order to prevent this, the device has an internal cancellation circuit. The measure of attenuation is Transhybrid Loss (THL).

## Transmit and Receive Gain

The Transmit Gain of the device is the gain from the balanced signal across Tip and Ring to the ground referenced signal at TX. It is set at 0dB.

The Receive Gain of the device is the gain from the ground referenced signal at RX to the balanced signal across Tip and Ring. It is set at -2dB.

## Supervision Features

### Line Status Detection Outputs

The MH88636-4 supervisory circuitry provides the signalling status outputs which are monitored by the

system controller. The supervisory circuitry is capable of detecting: Ringing Voltage; Forward and Reverse loop battery; Forward and Reverse loop current; and Switch Hook.

- **Ringing Voltage Detect Output ( $\overline{\text{RV}}$ )**

The  $\overline{\text{RV}}$  output provides a logic 0 when ringing voltage is detected across Tip and Ring. It toggles at the ringing frequency, typically going low 50ms after the ringing voltage is applied and remains low for 50 ms after ringing voltage is removed.

- **Forward Loop and Reverse Loop Detect Outputs ( $\overline{\text{FL}}$  &  $\overline{\text{RL}}$ )**

The  $\overline{\text{FL}}$  output provides a logic 0 when either forward loop battery or forward loop current is detected, that is the Ring pin voltage is negative with respect to Tip pin voltage.

The  $\overline{\text{RL}}$  output provides a logic 0 when either reverse loop battery or reverse loop current is detected, that is the Tip pin voltage is negative with respect to Ring pin voltage.

- **The Switch Hook Detect ( $\overline{\text{SHK}}$ )**

The  $\overline{\text{SHK}}$  output is active if either forward loop or reverse loop current is detected, or if forward or reverse battery voltage is detected.

## Control Inputs

The MH88636-4 accepts a control signal from the system controller at the Loop Relay Control input (LRC). This energises the relay drive output Loop Relay Drive ( $\overline{\text{LRD}}$ ). The output is active low and has an internal clamp diode to VRLY.

The intended use of this relay driver is to add and remove the Line Termination from across Tip and Ring, as shown in Figure 3.

If this Control input and the Supervisory Features are used as indicated in Figure 3, Loop-Start Signalling can be implemented.

## Mechanical Data

See Figure 9 and 10 for details of the mechanical specification.

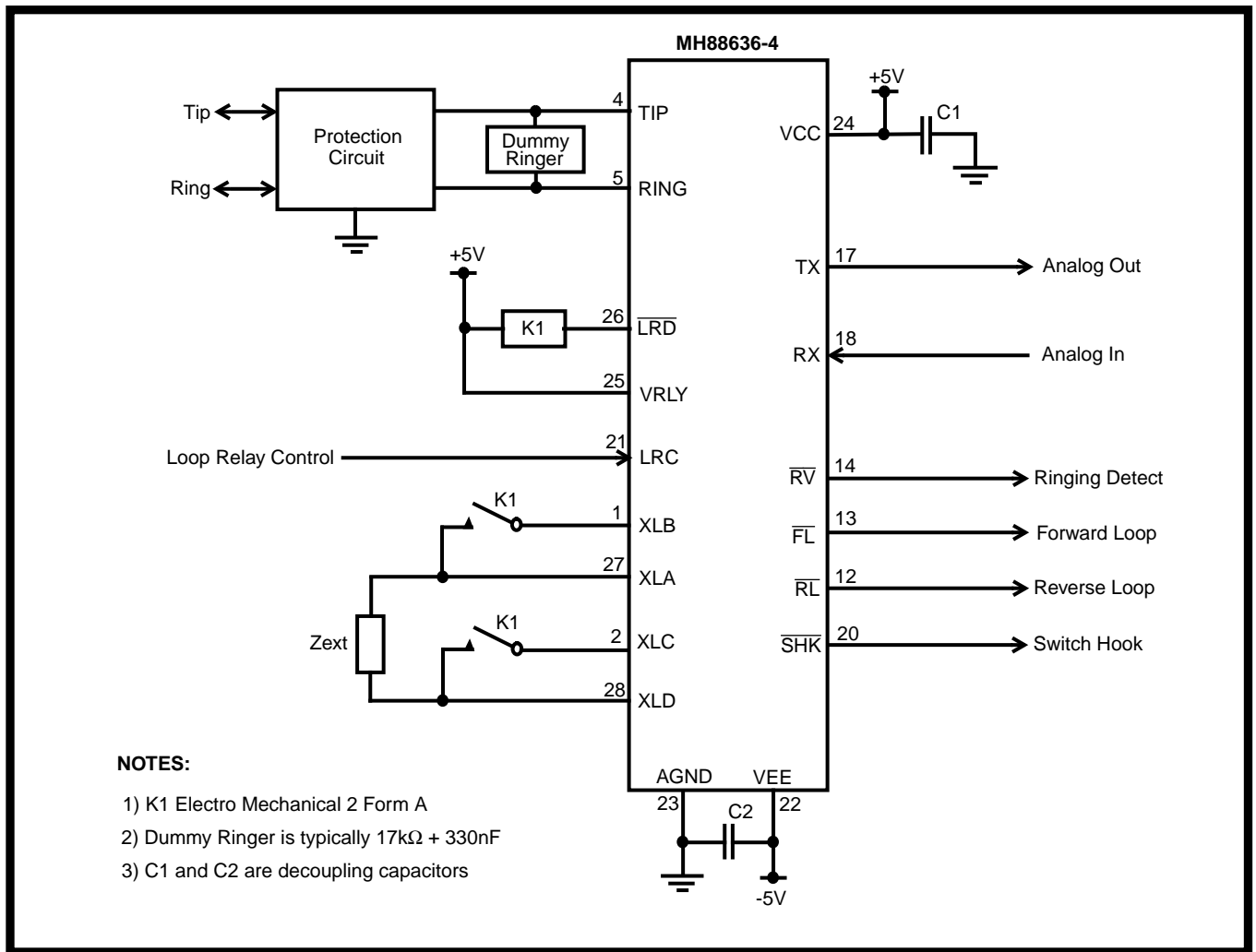

Figure 3 - Typical LS Application Circuit

## Absolute Maximum Ratings\*

	Parameters	Sym	Min	Max	Units	Comments
1	DC Supply Voltages	$V_{CC}$ $V_{EE}$	-0.3 0.3	7 -7	V	
2	DC Ring Relay Voltage	$V_{RLY}$	-0.3	18	V	
3	Storage Temperature	$T_S$	-55	+125	°C	
4	Ringing Voltage	$V_{RING}$		130	V <sub>rms</sub>	
5	Ring Trip Current	$I_{TR}$		180	mArms	250ms 10% duty cycle or 500ms single shot

\* Exceeding these values may cause permanent damage. Functional operation under these conditions is not implied.

## Recommended Operating Conditions

	Parameters	Symbol	Min	Typ <sup>‡</sup>	Max	Units	Comments
1	DC Supply Voltages	$V_{CC}$ $V_{EE}$	4.75 -4.75	5.0 -5.0	5.25 -5.25	V V	
2	DC Ring Relay Voltage	$V_{RLY}$		5.0	15	V	
3	Operating Temperature	$T_{OP}$	-40	25	85	°C	Industrial range MH88636AD-4I
			0	25	70	°C	Commercial range MH88636A*-4

‡ Typical figures are at 25°C with nominally ±5V supplies and are for design use only.

DC Electrical Characteristics<sup>†</sup>

		Characteristics	Sym	Min	Typ <sup>‡</sup>	Max	Units	Test Conditions
1		Supply Current	$I_{CC}$ $I_{EE}$		4 3	13 13	mA mA	
2		Power Consumption	PC		35	137	mW	
3	$\overline{FL}$ $\overline{RL}$ $\overline{SHK}$ $\overline{RV}$	Low Level Output Voltage	$V_{OL}$	-0.3		0.5	V	$I_{OL} = 4mA$
		High Level Output Voltage	$V_{OH}$	2.4		5.25	V	$I_{OH} = 0.4mA$
4	$\overline{LRD}$	Sink Current, Relay to $V_{CC}$ Clamp Diode Current	$I_{OL}$ $I_{CD}$	100 150			mA mA	$V_{OL} = 0.35V$
5	LRC	Low Level Input Voltage High Level Input Voltage	$V_{IL}$ $V_{IH}$			0.8	V V	
6	LRC	High Level Input Current Low Level Input Current	$I_{IH}$ $I_{IL}$			40 40	μA μA	$V_{IH} = 5.0V$

† Electrical Characteristics are over recommended operating conditions unless otherwise stated.

‡ Typical figures are at 25°C with nominally ±5V supplies and are for design use only.

**Loop Electrical Characteristics†**

	Characteristics	Symbol	Min	Typ‡	Max	Units	Test Conditions
1	Ring Voltage	RV	20		110	V <sub>rms</sub>	
2	Ring Frequency		16		68	Hz	
3	Operating Loop Current		16		70	mA	
4	Off-Hook DC Resistance			260	300 320	Ω	@ 20mA @ 16mA
5	Leakage Current (Tip-Ring to AGND)				7	mArms	@ 1000VAC
6	SHK & FL Threshold Tip-Ring (On-hook) Tip-Ring Current (Off-Hook)		14 5		20 15	Vdc mA	LRC = 0V LRC = 5V
7	SHK & RL Threshold Tip-Ring (On-Hook) Tip-Ring Current (Off-Hook)		-14 -5		-20 -15	Vdc mA	LRC = 0V LRC = 5V

† Electrical Characteristics are over recommended operating conditions unless otherwise stated .

‡ Typical figures are at 25°C with nominal ±5V supplies and are for design aid only.

## AC Electrical Characteristics†

	Characteristics	Symbol	Min	Typ‡	Max	Units	Test Conditions
1	2-wire Input Impedance	Z <sub>in</sub>		900		Ω	Programmed with Z <sub>EXT</sub> =1kΩ
2	Return Loss at 2-wire	RL	20	30		dB	Test circuit as Fig 6 200-3400 Hz Z <sub>in</sub> = 900Ω
3	Longitudinal to Metallic Balance		58 58 53 51			dB dB dB dB	Test circuit as Fig 7 200Hz 1000Hz 2000Hz 3000Hz-4000Hz
4	Metallic to Longitudinal Balance		60 40			dB dB	Test circuit as Fig 8 200Hz - 1kHz 1kHz - 4kHz
5	Transhybrid Loss	THL	20			dB	200-4000Hz
6	Gain (voltage) 2 wire to TX  Relative Gains		-0.25 -0.15 -0.25	0 0 0	+0.25 +0.15 +0.15	dB dB dB	Test circuit as Fig 4 1000Hz 300Hz 3400Hz
7	Gain (voltage) RX to 2 wire  Relative Gains		-2.25 -0.15 -0.25	-2 0 0	-1.75 +0.15 +0.15	dB dB dB	Test circuit as Fig 5 1000Hz 300Hz 3400Hz
8	Input impedance at RX			10		kΩ	
9	Output impedance at TX			5		Ω	
10	Signal Overload Level at 2-wire at TX		3.0 0			dBm dBm	% THD ≤ 5% Ref 900Ω @ 20mA
11	Total Harmonic Distortion at 2-wire at TX	THD		0.1 0.1	1.0 1.0	% %	Input 0.5V, 1kHz @ Rx Input 0.5V, 1kHz @ Tip-Ring
12	Idle Channel Noise at 2-Wire at TX	NC		11 13	16 16	dBrnC dBrnC	
13	Power Supply Rejection Ratio at 2-wire and TX V <sub>CC</sub> V <sub>EE</sub>	PSRR	25 25			dB dB	Ripple 0.1V, 1kHz
14	CMRR		50 40			dB dB	Test circuit as Fig 7 50Hz - 200Hz 200Hz - 4kHz
15	On-Hook Gain, 2-Wire to TX Relative to Off-Hook Gain		-1	0	1	dB	Input 1000Hz @ 0.5V

† Electrical Characteristics are over recommended operating conditions unless otherwise stated .

‡ Typical figures are at 25°C with nominal ±5V supplies and are for design aid only.



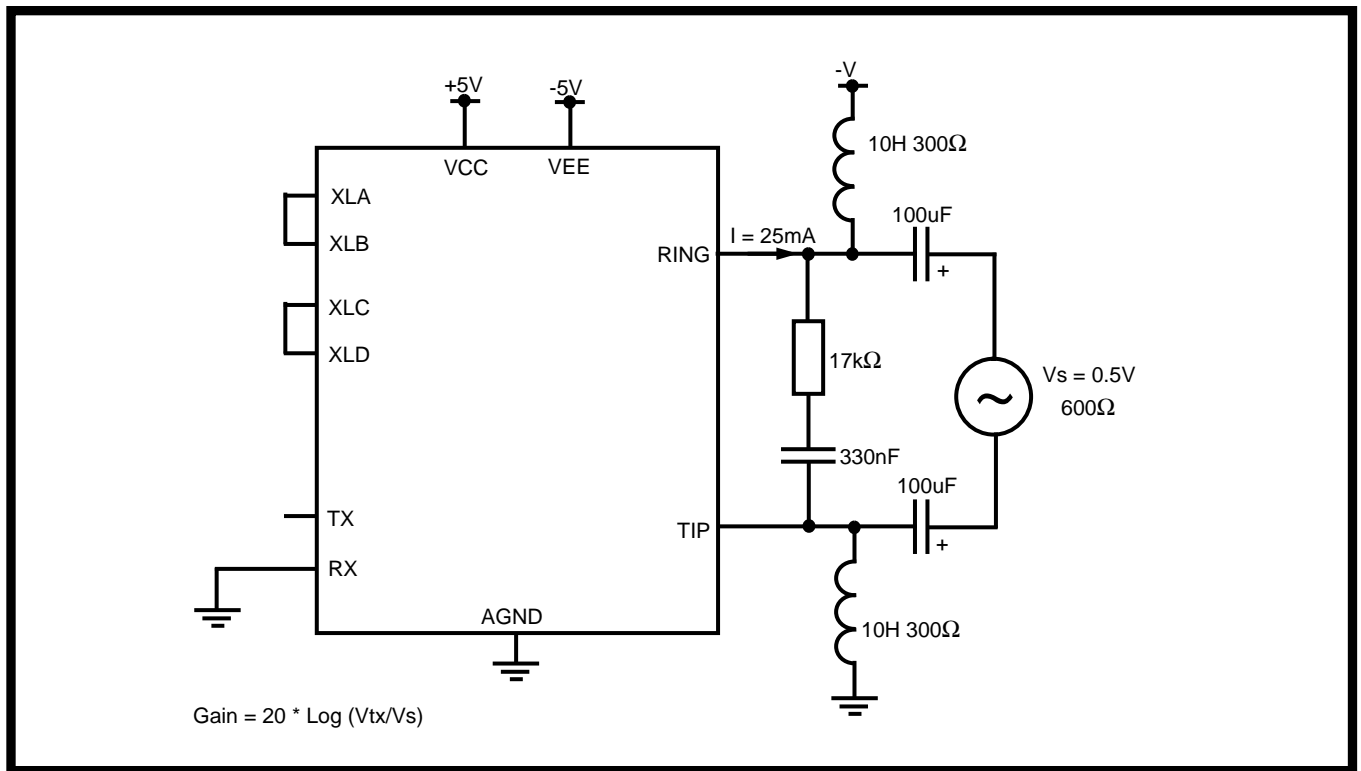

Figure 4 - 2-4 Wire Gain Test Circuit

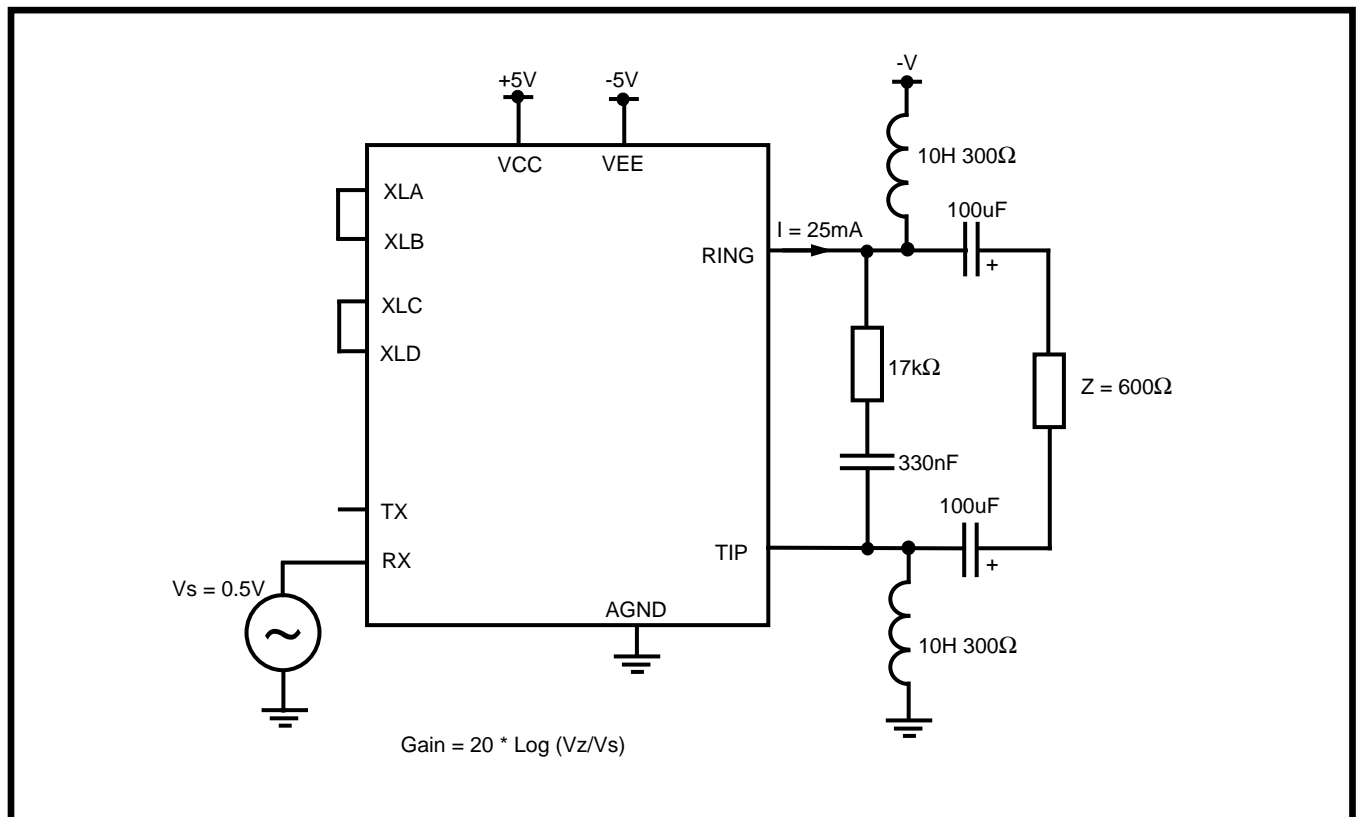

Figure 5 - 4-2 Wire Gain Test Circuit

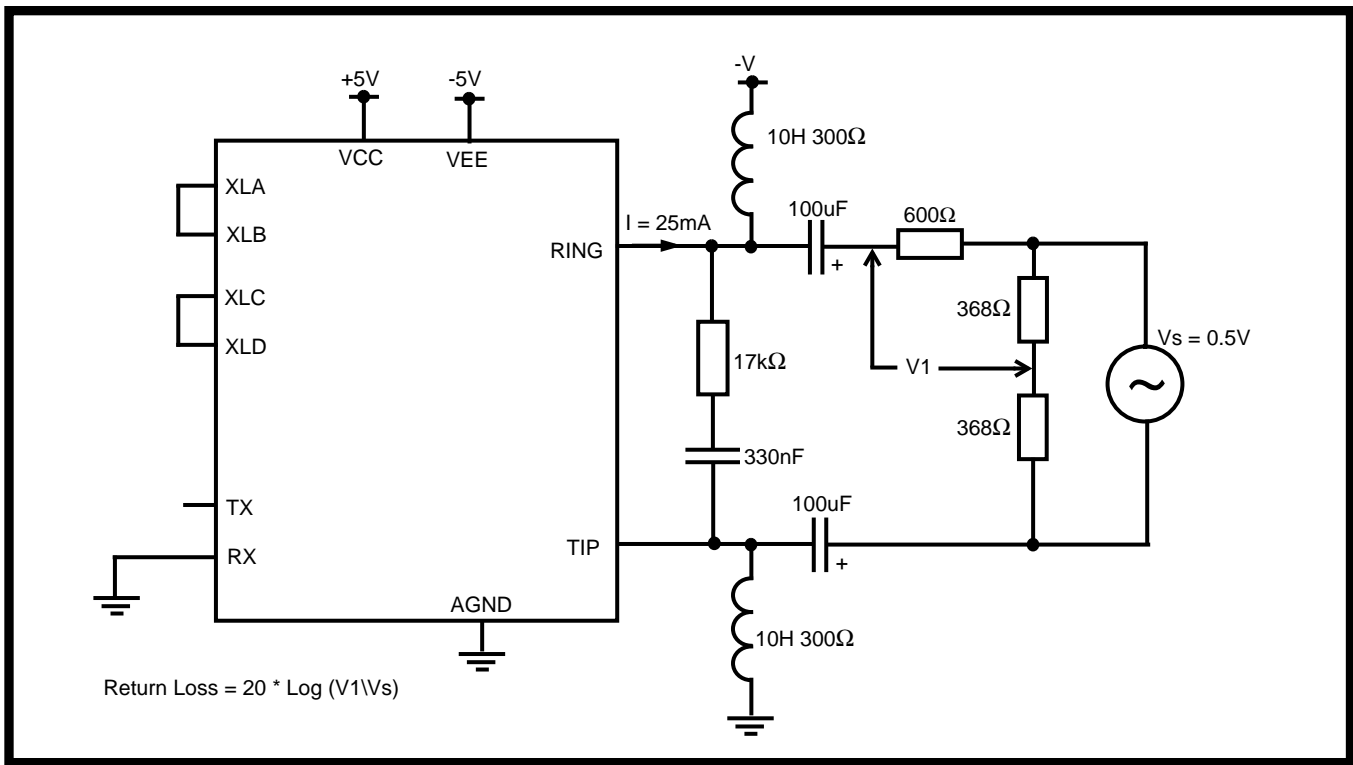

Figure 6 - Return Loss Test Circuit

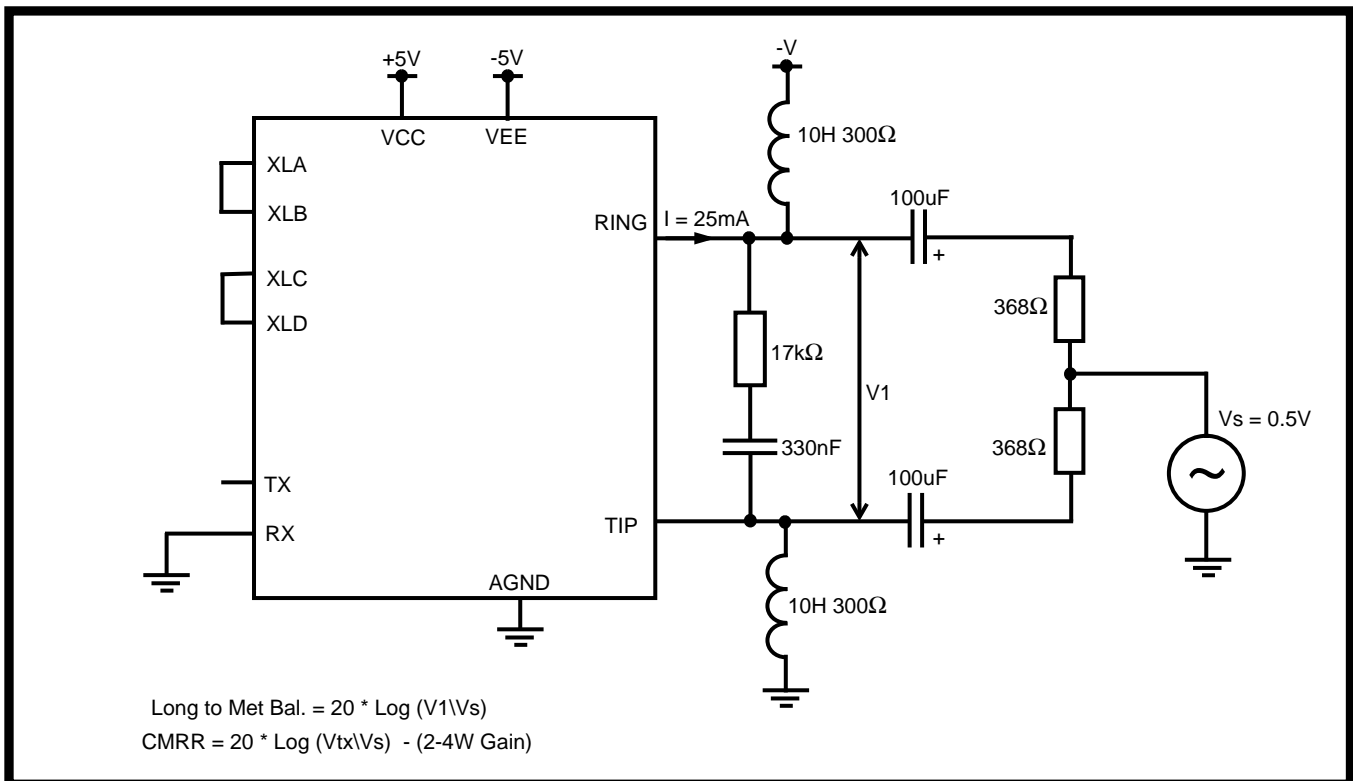

Figure 7 - Longitudinal to Metallic Balance and CMRR Test Circuit

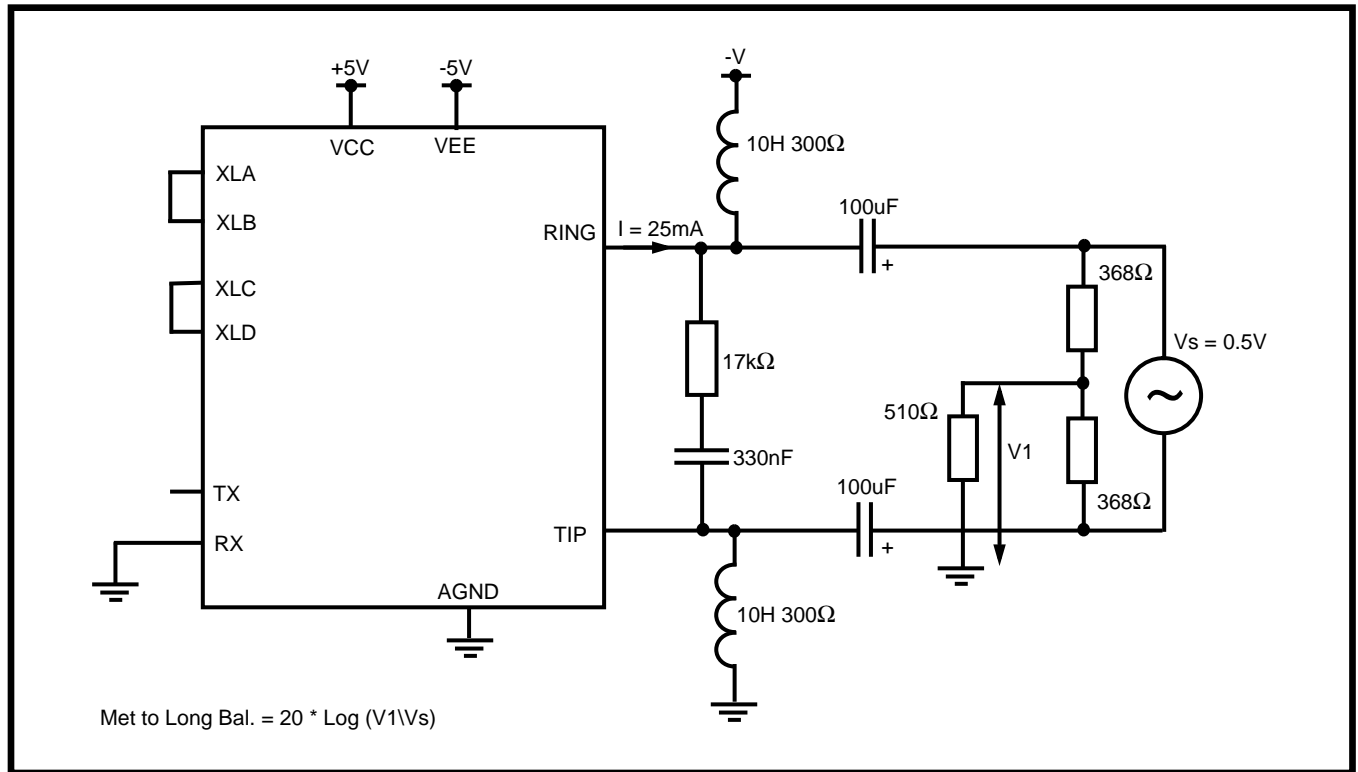

Figure 8 - Metallic to Longitudinal Balance Test Circuit

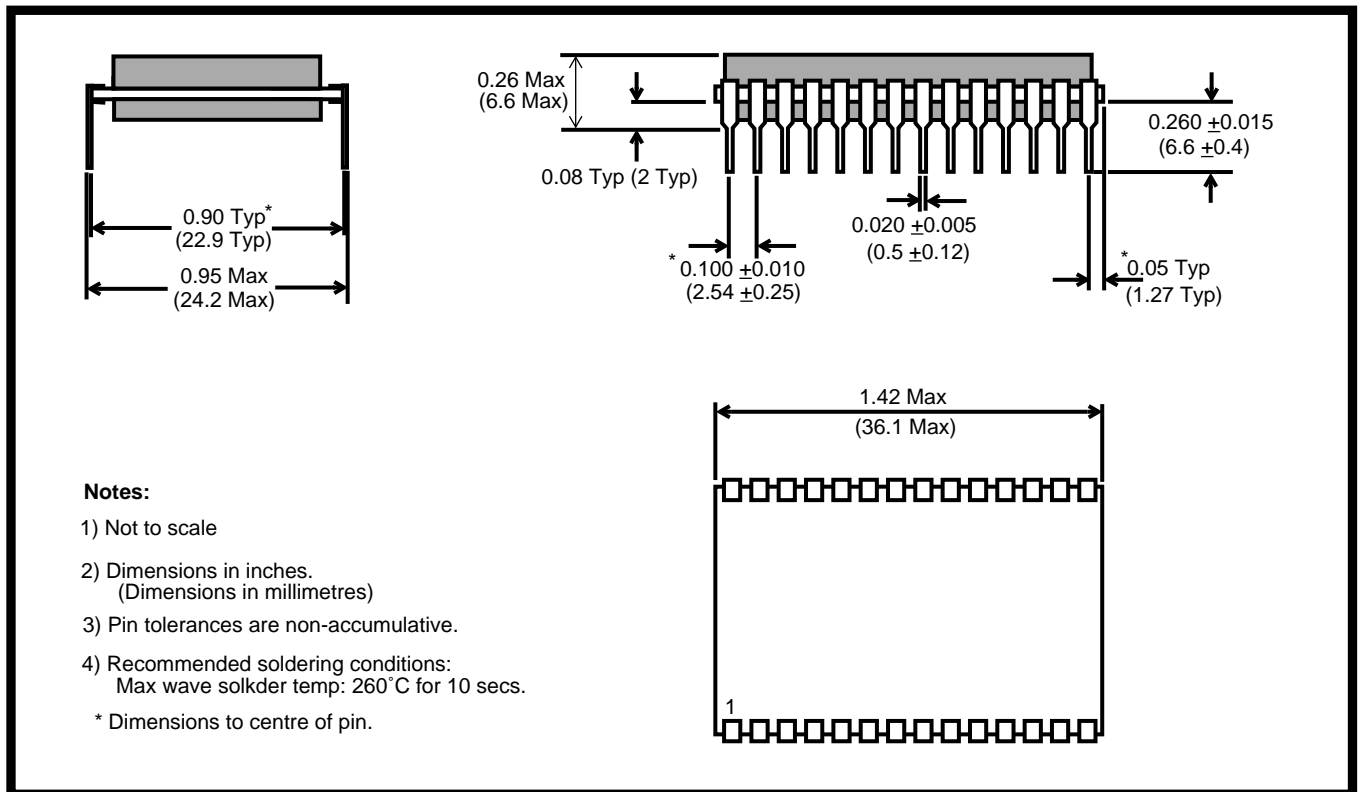

Figure 9 - DIL Package Mechanical Data

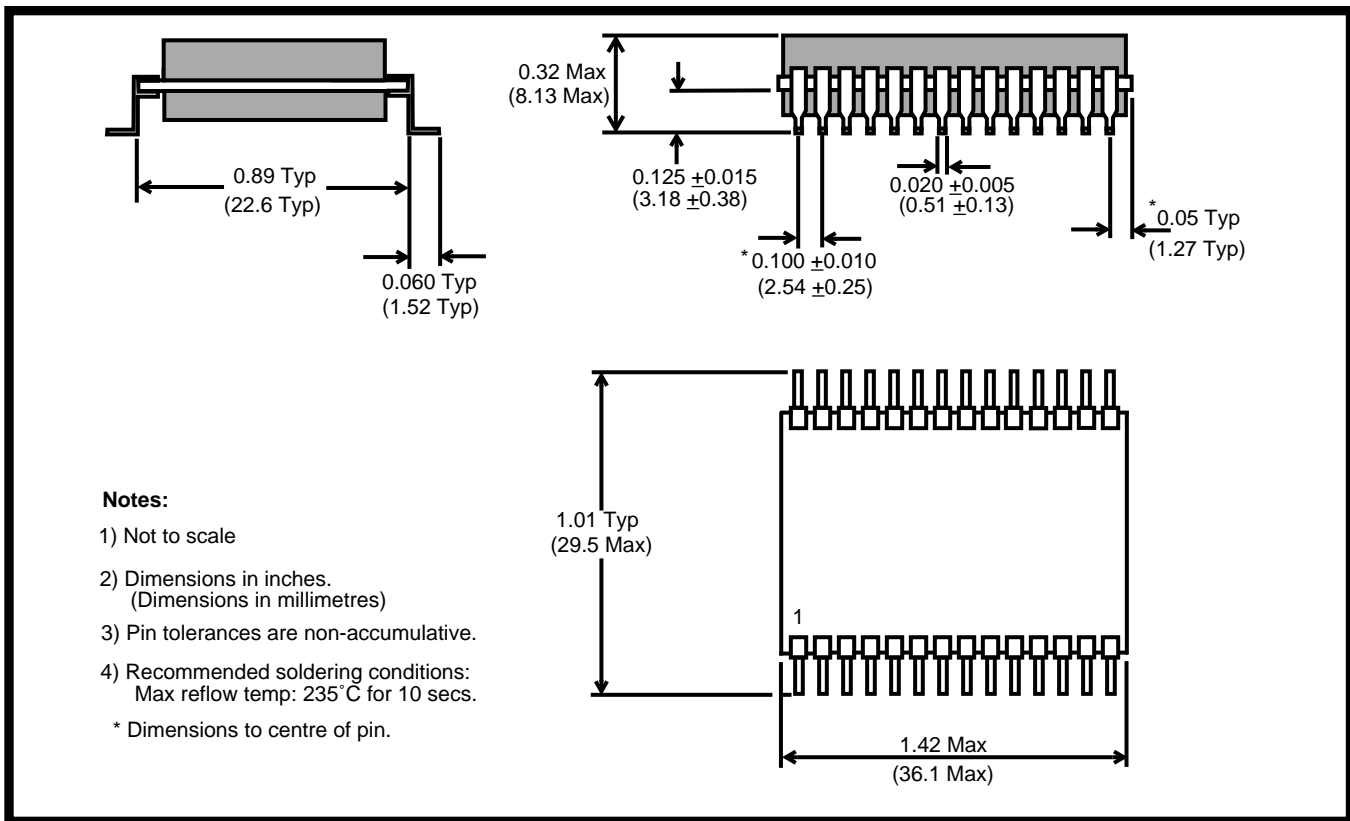

Figure 10 - SMT Package Mechanical Data

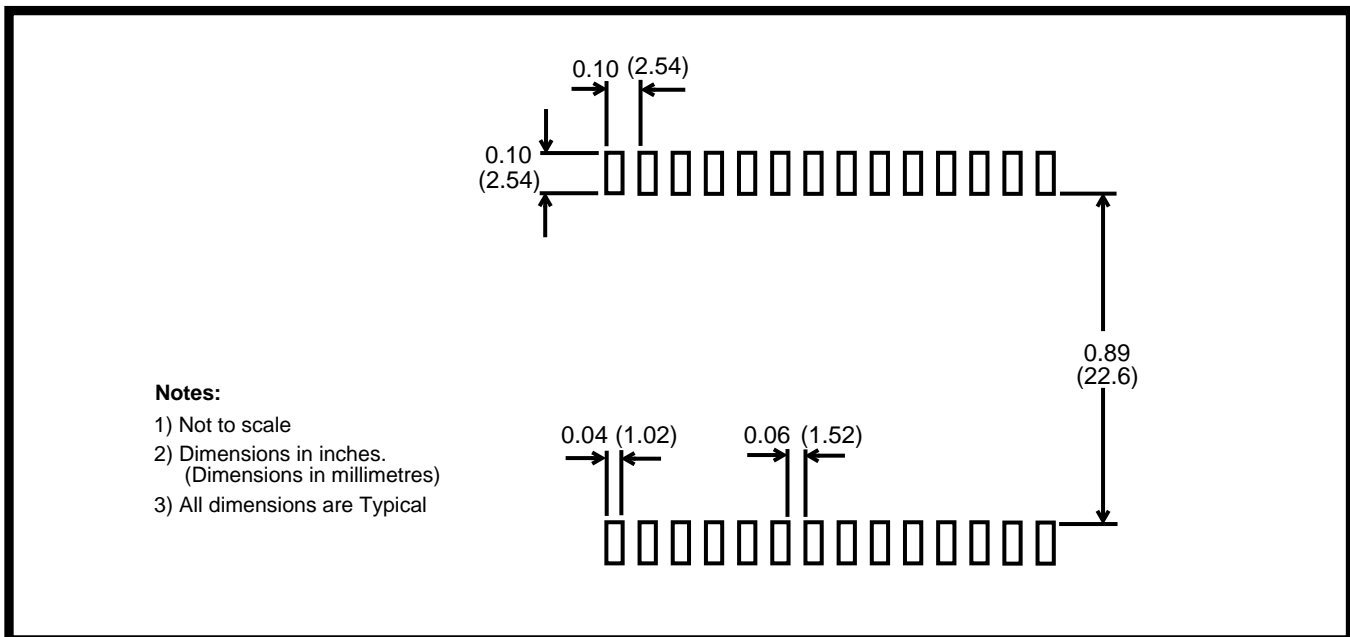

Figure 11 - SMT Footprint